



What: Cass County Commission Meeting

When: February 18, 2026, at 12:00 pm

Location: Historic Courthouse, 3rd Floor Conference Room, 102 E Wall Street, Harrisonville, MO 64701

AGENDA

The tentative agenda of this meeting includes:

Agenda Commission Meeting - 12:00 pm

- 1. Call to Order**
- 2. Roll Call**
- 3. Pledge of Allegiance**
- 4. Accept the Agenda as presented.**
- 5. Approval of Commission Meeting Minutes**
 - February 4, 2026
- 6. Approval of Work Session Minutes**
 - February 3, 2026 - Meet with Robert Schumacher
 - February 5 – Whistle blower protection
- 7. Resolution No. 26-13 – Cass County Treasurer’s Office**
 - Approving and authorizing annual Cass County Quarter cent Road and Bridge sales tax distribution to Cities, and payments to cities
 - Comment:
- 8. Resolution No. 26-14 – Cass County Commission**
 - A resolution authorizing the issuance of a Request for Qualifications for Construction Manager as Advisor Services for the Cass County old Historic Courthouse repair project.
 - Comment:
- 9. Resolution No. 26-15 – Cass County Road & Bridge Department**
 - A resolution approving a work order with Great River Engineering for engineering services related to Prairie Lane Bridge.
 - Comment:
- 10. Resolution No. 26-16 – Cass County Road & Bridge Department**
 - Accepting the bid of Murphy Tractor & Equipment Co. for purchase of a Craig Roller attachment for the Cass County Road & Bridge Department
 - Comment:
- 11. Resolution No. 26-17 – Cass County Road & Bridge Department**
 - A resolution accepting the bid of Redford Construction, INC. and authorizing execution of contract for the Davidson Road culvert replacement project
 - Comment:
- 12. Ordinance No. 26-04 – Cass County Road & Bridge Department**
 - An Ordinance authorizing the temporary posting of certain speed limits in connection with Highway 7 construction work.
 - Comment:
- 13. Cass County Collectors Office – Requesting disbursement of 2024 tax sale surplus monies**
 - Certificate of purchase # 24-01. Tax sale # 59, taxpayer name: Samantha & Jack Burton- Wilson, amount: \$37,067.92, payable to: Amanda Butler
 - Comment:
- 14. Public Comment (5-minute limit):**
- 15. Commissioner Communications:**
- 16. Adjourn**



The tentative agenda of this meeting may also include a vote to close part of the meeting pursuant to RS MO Sections:

	RSMo. 610.021.1 - Legal
	RSMo. 610.021.2 – Real Estate
	RSMo. 610.021.3 – Personnel Actions
	RSMo. 610.021.13 – Personnel Records
	RSMo. 610.021.18 – Confidential Communication with Auditor
	RSMo. 610.021.12 – Contract Negotiations



What: Cass County Commission Meeting

When: February 4, 2026 at 12:00 PM

Location: Historic Courthouse, 3rd Floor Conference Room.102 E Wall Street, Harrisonville, MO 64701

Bob Huston, Presiding Commissioner
Kathy Lambertz, County Clerk

Mike Moreland, Associate Commissioner District 1
Jeff Fletcher, Associate Commissioner District 2

Cass County Meeting Minutes

1. Call to Order

Presiding Commissioner Huston called the meeting to order at 12:00 PM.

2. Roll Call

Attendance	Name	Title
x	Bob Huston	Presiding Commissioner
	Mike Moreland	Associate Commissioner District 1
x	Jeff Fletcher	Associate Commissioner District 2

3. Pledge of Allegiance

4. Accept the agenda as presented.

Commissioner Fletcher made a motion to accept the agenda.

Presiding Commissioner Huston seconded the motion to accept the agenda.

Motion Status: Passed 2-0

5. Approval of Commission Meeting Minutes

- January 21, 2026

Commissioner Fletcher made a motion to accept the Minutes.

Presiding Commissioner Huston seconded the motion to accept the Minutes.

Motion Status: Padded 2-0

6. Approval of Work Session Minutes

- January 14, 2026 – Bike MS ride

Commissioner Fletcher made a motion to accept the Minutes.

Presiding Commissioner Huston seconded the motion to accept the Minutes.

Motion Status: Passed 2-0

7. Resolution No. 26-09 – Cass County Emergency Management

- Adopting the Cass County Emergency Operations Plan
- Comment: Emergency Management Justin Crane gave an update.

Commissioner Fletcher made a motion to accept Resolution No. 26-09.

Presiding Commissioner Huston seconded the motion to accept Resolution No. 26-09.

Motion Status: Passed 2-0

8. Resolution No. 26-10 – Cass County Commission

- Approving a services agreement with Graves Garrett Greim, LLC
- Comment:

Commissioner Fletcher made a motion to accept Resolution No. 26-10.
Presiding Commissioner Huston seconded the motion to accept Resolution No. 26-10.
Motion Status: Passed 2-0

9. Resolution No. 26-11 – Cass County Sheriff's Office

- Approving participation in the Missouri Highway Safety Program
- Comment: Lieutenant Claibourn gave an update.

Commissioner Fletcher made a motion to accept Resolution No. 26-11.
Presiding Commissioner Huston seconded the motion to accept Resolution No. 26-11.
Motion Status: Passed 2-0

10. Ordinance No. 26-03 – Cass County Codes & Zoning Department

- An ordinance amending County Code Chapter 700, article I related to wastewater treatment systems.
- Comment: Codes & Zoning Director Valerie McCubbin gave an update.

Commissioner Fletcher made a motion to accept Ordinance No. 26-03.
Presiding Commissioner Huston seconded the motion to accept Ordinance No. 26-03.
Motion Status: Passed 2-0

11. For the Record – Cass County Collector's Office – Abatements

- 2023 Personal Property Abatement # 569
- 2024 Personal Property Abatement # 585-588
- 2025 Personal Property Abatement # 418 425-449, 550, 552-556

12. Public Comment (5-minute limit): Richard Strader 312 Frederick - voiced some concerns happening in Dikeland. Scott Inmens asked about the 70 acres west of the Justice Center

13. Commissioner Communications:

14. Adjourn

Commissioner Fletcher made a motion to adjourn at 12:27 PM.
Presiding Commissioner Huston seconded the motion to adjourn.
Motion Status: Passed 2-0



Executive Session:

The tentative agenda of this meeting also includes a vote to close part of the meeting pursuant to RSMO Sections:

x	RSMo. 610.021.1 - Legal
	RSMo. 610.021.2 – Real Estate
	RSMo. 610.021.3 – Personnel Actions
	RSMo. 610.021.13 – Personnel Records
	RSMo. 610.021.18 – Confidential Communication with Auditor
	RSMo. 610.021.12 – Contract Negotiations

Commissioner Fletcher made a motion to enter Executive Session and the meeting be closed at 12:07 PM pursuant to (See Above)

Presiding Commissioner Huston seconded the motion and it passed unanimously by roll call vote.

Commissioner Fletcher moved to adjourn from Executive Session and reconvene into regular session at 12:27 PM.

Presiding Commissioner Huston seconded the motion and it passed unanimously by roll call vote.

Bob Huston
Presiding Commissioner

Mike Moreland
Associate Commissioner District 1

Jeff Fletcher
Associate Commissioner District 2

Kathy Lambertz
County Clerk

Minutes Approval Date: _____



Cass County Commission – Work Session Minutes

What: Meeting with Robert Schumacher discussing sewer regulations

When: February 3, 2026

Time Started: 10:00 am

Time Ended: 11:00 am

Location: Historic Courthouse, 3rd floor conference room

Address: 102 E Wall Street, Harrisonville, MO 64701

Attendance	Name	Title
x	Bob Huston	Presiding Commissioner
x	Mike Moreland	Associate Commissioner District 1
x	Jeff Fletcher	Associate Commissioner District 2
x	Kathy Lambertz	County Clerk
x	Robert Schumacher	Owner, Robert T Schumacher LLC Enterprises
x	Eric Thompson	
x	Steve Bockelman	

1. Call to Order

2. Roll Call:

General Topics of Discussion

Discussed the sewer regulations.

Prepared By: Kayleigh Bowes



Cass County Commission – Work Session Minutes

What: Amending the General Personnel Policy Manual

When: 2-5-2026

Time Started: 10:00 am

Time Ended: 10:15 am

Location: Historic Courthouse, 3rd Floor Conference Room

Address: 102 E Wall Street, Harrisonville, MO 64701

Attendance	Name	Title
x	Bob Huston	Presiding Commissioner
x	Mike Moreland	Associate Commissioner District 1
x	Jeff Fletcher	Associate Commissioner District 2
x	Holly Braswell	Human Resource

1. Call to Order
2. Roll Call:

General Topics of Discussion

Adding section 2.14 to the Personnel Policy Manual regarding whistle blower protection
Commission believes they need the policy.

Commissioner Fletcher motioned to approve Resolution No. 26-12; Commissioner Moreland seconded the motion. Vote 3-0

Commissioner Fletcher motioned to adjourn the meeting; Commissioner Moreland seconded the motion.
Vote 3-0

Prepared By: Kayleigh Bowes

Certified Copy of Record

STATE OF MISSOURI, }
County of Cass, } ss.

In the County Commission of Cass County, Missouri, at the January Term, 2026, held on the 18th day of February 2026 amongst others, were the following proceedings:

RESOLUTION NO. 26-13 OF THE CASS COUNTY COMMISSION

APPROVING AND AUTHORIZING ANNUAL CASS COUNTY QUARTER CENT ROAD AND BRIDGE SALES TAX DISTRIBUTION TO CITIES, AND PAYMENTS TO CITIES

NOW, THEREFORE, BE IT HEREBY RESOLVED AND ORDERED BY THE COUNTY COMMISSION OF CASS COUNTY, MISSOURI, THAT, this Commission hereby approves and authorizes payments to be made to cities and villages from the Quarter Cent Road and Bridge Sales Tax revenue, in the amounts listed on Appendix A, which is attached hereto and incorporated herein, with said payments to be made within 30 days of the approval of this Resolution, or as soon after such time as is reasonable and practical.

ADOPTED BY THE COUNTY COMMISSION OF CASS COUNTY, MISSOURI, THIS 18th DAY OF FEBRUARY 2026.

Bob Huston
Presiding Commissioner

Mike Moreland
Associate Commissioner
Dist. 1

Jeff Fletcher
Associate Commissioner
Dist. 2

ATTEST:



Kathy Lambertz
County Clerk

Dated: _____

City R&B Sales Tax Disbursement - YR 2025

	Amount of 1/4 Cent Sales Tax to Pay	
Belton	\$403,105.35	
Raymore	\$404,679.67	
Harrisonville	\$162,884.31	
Pleasant Hill	\$147,443.52	
Peculiar	\$110,944.57	
Garden City	\$46,926.15	
Lake Winnebago	\$49,430.44	
Archie	\$42,498.68	
Drexel	\$38,002.04	
Cleveland	\$33,699.09	
Freeman	\$31,679.06	
Creighton	\$29,396.14	
East Lynne	\$28,981.07	
Strasburg	\$26,393.77	
Lake Annette	\$26,338.42	
West Line (v)	\$18,181.56	
Baldwin Park (v)	\$17,683.47	
Gunn City (v)	\$17,628.13	
Riverview Estates (v)	\$17,614.29	
Total:	\$1,653,509.74	The above actually totals \$1,653,509.73, which is fine.

Certified Copy of Record

STATE OF MISSOURI, }
County of Cass, } ss.

In the County Commission of Cass County, Missouri, at the January Term, 2026, held on the 18th day of February 2026 amongst others, were the following proceedings:

RESOLUTION NO. 26-14 OF THE CASS COUNTY COMMISSION

A RESOLUTION AUTHORIZING THE ISSUANCE OF A REQUEST FOR QUALIFICATIONS FOR CONSTRUCTION MANAGER AS ADVISOR SERVICES FOR THE CASS COUNTY OLD HISTORIC COURTHOUSE REPAIR PROJECT.

BE IT HEREBY RESOLVED AND ORDERED BY THE COUNTY COMMISSION OF CASS COUNTY, MISSOURI, THAT the County Commission approves and authorizes the issuance of a Request for Qualifications for Construction Manager as Advisor services for the Cass County Old Historic Courthouse Repair Project, substantially in the form attached hereto. The Presiding Commissioner, County Clerk, and such other County officials or staff as may be appropriate are hereby authorized to take such administrative actions as are reasonably necessary to publish, distribute, receive, and evaluate responses to the Request for Qualifications.

ADOPTED BY THE COUNTY COMMISSION OF CASS COUNTY, MISSOURI, THIS 18TH DAY OF FEBRUARY 2026.

Bob Huston
Presiding Commissioner

Mike Moreland
Associate Commissioner
Dist. 1

Jeff Fletcher
Associate Commissioner
Dist. 2

ATTEST:

Kathy Lambertz
County Clerk
Dated: _____



NOTICE REQUESTING PROPOSALS

Cass County, Missouri is requesting and soliciting proposals from qualified construction managers for construction management as advisor services in connection with the Cass County Old Historic Courthouse Repair Project, consisting of repair and restoration of the historic structure. Construction management services may include services during the preconstruction phase, the construction phase, or both, as authorized by §§ 8.675–8.687, RSMo. Proposals shall be submitted in accordance with the Request for Qualifications issued by Cass County and must be received no later than [REDACTED], 2026 by Noon. Four copies must be submitted to: Cass County Commission, c/o Kayleigh Bowes, 102 East Wall Street, Harrisonville, Missouri 64701. The Request for Qualifications may be obtained from the County's website (www.casscounty.com) or by contacting Kayleigh Bowes at kayleighb@casscounty.com.

Cass County Commission

REQUEST FOR QUALIFICATIONS
Construction Manager as Advisor Services
Cass County Old Historic Courthouse Repair Project
Cass County, Missouri

1. Project Description

The Project consists of repair and restoration work at the Cass County Old Historic Courthouse, including temporary structural support, removal and reinstallation of historic brick and masonry elements, and related repairs necessary to preserve the historic structure. The County seeks to engage a Construction Manager as Advisor to provide construction management services as defined in § 8.675, RSMo. The Construction Manager will provide services during the preconstruction phase, the construction phase, or both, as determined by the County. The Project includes, at a minimum, the following construction elements, which shall inform the Construction Manager's services:

1. Temporary support of a corner of an existing column in a designated area.
2. Installation of a temporary metal column to allow removal of an existing brick column.
3. Careful removal, cleaning, and reinstallation of existing brick. Replacement brick, if required, shall match existing brick as closely as possible in visual appearance.
4. Removal and replacement of mortar in affected brick walls.
5. Use of Type "O" limestone-based mortar, suitable for historic masonry, with minimal Portland cement to ensure flexibility and compatibility with fragile historic brick.
6. Replacement mortar color shall match existing mortar as closely as possible in visual appearance.
7. No bond adhesives shall be used.
8. Mortar texture, tooling, and finish shall match existing conditions.

Consistent with §§ 8.683 and 8.685, RSMo:

1. The Construction Manager shall not bid on or perform any actual construction work on the Project.
2. No construction firm that controls, is controlled by, or shares common ownership or control with the Construction Manager may bid on or perform construction work on the Project.
3. The Construction Manager shall not guarantee, warrant, or assume financial responsibility for the work of others.
4. The Construction Manager shall not provide a guaranteed maximum price (GMP).
5. The Construction Manager shall not furnish or guarantee performance or payment bonds for contractors.
6. All construction work shall be awarded by competitive bidding and all contractors shall contract directly with the County.

2. Selection Procedure

This RFQ is issued pursuant to § 8.679, RSMo. In selecting a Construction Manager, the County will consider the criteria set forth in § 8.681, RSMo, including, but not limited to:

- Qualifications and experience with comparable projects
- Ability to perform construction management services of similar scope and complexity
- Experience managing historic or masonry restoration projects
- Qualifications of personnel assigned to the Project
- Financial strength and management systems

The County may negotiate a contract for construction management services with any selected construction manager in accordance with law. The County reserves the right to reject any or all submissions, waive informalities, and to take such actions as it deems to be in the best interest of the County.

3. Submission Requirements

Each respondent shall submit a statement of qualifications that includes:

1. Firm name, address, and primary contact information.
2. Description of the firm's experience providing construction management services under §§ 8.675–8.687, RSMo.
3. Description of experience on projects comparable in scope, complexity, and historic nature.
4. Identification and qualifications of key personnel proposed for the Project.
5. References for public owners for whom construction management services have been performed.

4. Fees

Fees for construction management services, including overhead, profit, and reimbursable costs, shall be negotiated with the selected construction manager in accordance with § 8.681, RSMo. Fee proposals are not requested and shall not be submitted with responses to this RFQ.

5. Submission Deadline

Qualifications must be received by: by Noon.

Four copies must be submitted to: Cass County Commission, c/o Kayleigh Bowes, 102 East Wall Street, Harrisonville, Missouri 64701.

6. Addenda

Any addenda issued to this RFQ shall be posted on County's website.

Certified Copy of Record

STATE OF MISSOURI, }
County of Cass, } ss.

In the County Commission of Cass County, Missouri, at the January Term, 2026, held on the 18th day of February 2026 amongst others, were the following proceedings:

RESOLUTION NO. 26-15 OF THE CASS COUNTY COMMISSION

A RESOLUTION APPROVING A WORK ORDER WITH GREAT RIVER ENGINEERING FOR ENGINEERING SERVICES RELATED TO PRAIRIE LANE BRIDGE

NOW, THEREFORE, BE IT HEREBY RESOLVED AND ORDERED BY THE COUNTY COMMISSION OF CASS COUNTY, MISSOURI, THAT, this Commission hereby approves the attached Work Order identified as No. 4493.24 for engineering services related to Prairie Lane Bridge #0350023, in the amount of \$27,500.00. The Presiding Commissioner is hereby authorized to sign the agreement on behalf of Cass County, Missouri, and all other documents necessary to facilitate this order.

ADOPTED BY THE COUNTY COMMISSION OF CASS COUNTY, MISSOURI, THIS 18TH DAY OF FEBRUARY 2026.

Bob Huston
Presiding Commissioner

Mike Moreland
Associate Commissioner
Dist. 1

Jeff Fletcher
Associate Commissioner
Dist. 2

ATTEST:



Kathy Lambertz
County Clerk

Dated: _____

4493.24 Work Order

The **AGREEMENT BETWEEN CLIENT AND CONSULTANT FOR PROFESSIONAL SERVICES** dated 04/04/2022 for General Engineering Services is hereby amended and supplemented to include the following agreement of the parties:

 Great River Associates, Inc. (dba Great River Engineering)
Company address -
Company ID no. -
Hereinafter referred to as Consultant

AND

Cass County, MO

Hereinafter referred to as Client

EXHIBIT A – SCOPE OF SERVICES

PART 1 – BASIC SERVICES

Add the following services:

Prairie Lane Bridge #0350023

The Engineer will:

1. Perform a site assessment and work with County to assess needs for the project. Objective will be to replace existing structure with a new single span aluminum box culvert.
2. Submit Softmatch Credit Pre-Approval Form to MoDOT.
3. Generate site contours using publicly available LiDAR data and key field survey shots. *Full topographic survey is not anticipated.*
4. Evaluate design alternatives, develop preliminary plans, and recommend to the County the overall general design based on these studies.
5. Prepare detailed construction plans, cost estimates, specifications and related documents as necessary for the purpose of soliciting bids for supplying the project;
6. Secure adequate property title information, determine right-of-way plans, and conveyance documents.
7. Conduct property owner negotiations on behalf of the County. Negotiation efforts include: one site meeting with all property owners and two follow-up phone calls or written correspondence per parcel. Negotiations will be conducted for 2 parcels.
8. Acquire right-of-way and easements by donation or just compensation. *Appraisal services and acquisition through eminent domain or relocation are not included in this scope.*
9. Submit Pre-construction Notification Form to the U.S. Army Corps of Engineers. *Wetland analysis is not included in this scope of work.*
10. Submit a no-rise certificate to the County Floodplain Administrator.

11. Submit a Floodplain Development permit to the County Floodplain Administrator.
12. Submit Section 106 permit application to DNR State Historic Preservation Office.
13. Obtain United States Fish and Wildlife (USF&W) and Missouri Department of Conservation (MDC) species list.
14. Perform one-time construction staking for the layout of the new structure.
15. Check shop drawings submitted by the suppliers. *Supplier to provide sealed structure load ratings calculations.*
16. Be present during the following critical construction operations to observe the progress and quality of work, and to determine if the work conforms to the contract documents:
 - 16.1. Checking of reinforcing steel and concrete pouring (1 trip)
 - 16.2. Participate in final inspection (1 trip)
17. Provide MoDOT with project documentation to obtain softmatch credit (*pending eligibility*).

The County to:

1. Provide labor, material, and equipment records as well as construction daily log.
2. Coordinate with any utility conflicts.

EXHIBIT B – PAYMENTS TO CONSULTANT FOR SERVICES AND REIMBURSABLE EXPENSES

Add the following:

B.5 Compensation For Basic Services – Lump Sum Method of Payment

Client shall pay Consultant for Basic Services set forth in Work Order Exhibit A as follows: A Lump Sum amount of \$27,500.00.

3. The Lump Sum includes compensation for Consultant's services and services of Consultant's Sub-Consultants, if any. Appropriate amounts have been incorporated in the Lump Sum to account for labor, overhead, profit, and Reimbursable Expenses.
4. The portion of the Lump Sum amount billed for Consultant's services will be based upon Consultant's estimate of the proportion of the total services actually completed during the billing period to the Lump Sum.

ACCEPTANCE BY PARTIES:

The Consultant offers this Work Order to Client and if said Work Order is not fully executed by Client within 30 days of Consultant's signature, said offer of Work Order will be null and void.

Full name Spencer Jones (Principal)
On behalf of Great River Associates, Inc. (dba Great River Engineering)
Email spencer@greatriv.com
IP Address -
Signature will appear here

On behalf of
Cass County, MO

Bob Huston
Presiding Commissioner

Date: _____



Certified Copy of Record

STATE OF MISSOURI, }
County of Cass, } ss.

In the County Commission of Cass County, Missouri, at the January Term, 2026, held on the 18th day of February 2026 amongst others, were the following proceedings:

RESOLUTION NO. 25-16 OF THE CASS COUNTY COMMISSION

ACCEPTING THE BID OF MURPHY TRACTOR & EQUIPMENT CO. FOR PURCHASE OF A CRAIG ROLLER ATTACHMENT FOR THE CASS COUNTY ROAD & BRIDGE DEPARTMENT

BE IT HEREBY RESOLVED AND ORDERED BY THE COUNTY COMMISSION OF CASS COUNTY, MISSOURI, THAT, this Commission hereby approves the bid of Murphy Tractor & Equipment Co. in the amount of \$31,900.00 for the purchase of one (1) Craig MG-CGP-9611 Gravel Packer (roller attachment). The Presiding Commissioner or his designee is hereby authorized to sign necessary agreements on behalf of Cass County, Missouri, and all other documents necessary to facilitate this order.

ADOPTED BY THE COUNTY COMMISSION OF CASS COUNTY, MISSOURI, THIS 18TH DAY OF FEBRUARY 2026.

Bob Huston
Presiding Commissioner

Mike Moreland
Associate Commissioner
Dist. 1

Jeff Fletcher
Associate Commissioner
Dist. 2

ATTEST:



Kathy Lambertz
County Clerk

Dated: _____



CASS COUNTY ROAD & BRIDGE DEPARTMENT
816-380-8360
30508 SOUTH WEST OUTER ROAD
HARRISONVILLE, MISSOURI 64701



Walk-N-Roll Bid Sheet

February 6th, 2026

Business Name

Bid Amount

Road Builders

\$ 32,550.00

Murphy Tractor

\$ 31,900.00

Quote # 1557273

Exp. 28-Feb-2026

Balance Due

\$31,900.00

Description

LyCox Enterprises WR90 Construction Attachments

QTY Selling Price

1 \$31,900.00

Subtotal

\$31,900.00

Total Selling Price

\$31,900.00

Total Tax

\$0.00

Sub Total

\$31,900.00

Prepared For

Balance Due

\$31,900.00

CASS COUNTY ROAD AND BRIDGE

102 E WALL ST
HARRISONVILLE, MO 647012451

Prepared By

Chuck Kaiser
8600 NE Parvin Road
KANSAS CITY, MO 64161

Mobile Phone: 816-519-9739

Configurations

LyCox Enterprises WR90 Construction Attachments

QTY 1

Base / Options

JD770 Quick Attach

1

JD Spacer

1



Road Builders Machinery and Supplies Co.
 Kansas City KS
 Presented by:
Jeremy Manning

Quote #: jpm-0586
 1/14/2026 3:05 PM
 Page 1 of 4
 816-898-9728
 jmanning@rbmsco.com

Billing Address:

CASS COUNTY ROAD & BRIDGE CASS005
 30508 SW OUTER RD
 HARRISONVILLE MO 64701
 Main Phone# 8163808360

Shipping Address:

Kansas City Store
 1001 S 7th St Trafficway
 Kansas City KS 66105

Sales Quote

**Qty: 1 2026 Craig Grader Packer--MG-CGP-96II S/N Factory Order, STOCK # N.I.S.
 \$32,550.00 each**

Equipped as follows:

CRAIG GRADER PACKER
 96" - 12 X SMOOTH ROLLER TIRES ON HEAVY DUTY RIMS
 3 X PACKER LIFT CYLINDER AND LIFT ASSEMBLY
 1 X HYDRAULIC ACCUMULATOR TO ENSURE CONTACT IS MAINTAINED WITH THE ROAD SURFACE
 1 X SIDE SHIFT CYLINDER – 24" OF TRAVEL – CAN BE MANUALLY SWITCHED TO EITHER SIDE OF PACKER
 ADJUSTABLE PACKER FRAME TO ALLOW FOR COMPACTION OUTSIDE OF GRADER PATH OF TRAVEL.
 ALL AXLES ARE HEAVY DUTY AND HAVE A 6,000 LBS CAPACITY
 SPECIAL NOTES: **GRADER WILL REQUIRE TWO FREE HYDRAULIC CIRCUITS TO OPERATE THE PACKER – ONE FOR
 LIFT AND ONE FOR SIDE SHIFT. JUMPER HOSES NOT SUPPLIED
 COMES WITH CRAIG REAR POST BRACKET
 HYDRAULICALLY ADJUSTABLE TO TRAVEL UP TO 24" ON EITHER SIDE OF GRADER
 NOTE: CYLINDER MUST BE MANUALLY MOVED AND CAN ONLY BE USED ON ONE SIDE AT A TIME.
 COMPLETE WITH DOWN PRESSURE FLOAT BAR – THIS BAR CONNECTS ALL PACKER ARMS AND ENSURES
 MAXIMUM COMPACTION TO THE ROAD SURFACE

Standard Options

Quote Amount

Sale Price: \$32,550.00

Total Selling Price: \$32,550.00

- **Lead time 10-11 weeks from date of order
- **Mount plate included and will match Deere 770 grader
- **FOB from Roadbuilders Kansas City location, and freight included from the factory to Roadbuilders
- **Cass County providing installation

** Subject to all applicable taxes. This proposal is good for 30 days and subject to availability. Pricing is subject to change without notice.*



Road Builders Machinery and Supplies Co.

Kansas City KS

Presented by:
Jeremy Manning

Quote #: jpm-0586

1/14/2026 3:05 PM

Page 2 of 4

816-898-9728

jmanning@rbmsco.com

On behalf of RoadBuilders Machinery & Supplies Co., thank you for the opportunity to quote this
Craig MODEL Grader Packer--MG-CGP-96II Accessory Serial Number Factory Order Stock Number N.I.S..

Sincerely,

Jeremy Manning
District Sales Rep

** Subject to all applicable taxes. This proposal is good for 30 days and subject to availability. Pricing is subject to change without notice.*



Road Builders Machinery and Supplies Co.
 Kansas City KS
 Presented by:
Jeremy Manning

Quote #: jpm-0586
 1/14/2026 3:05 PM
 Page 3 of 4
 816-898-9728
 jmanning@rbmsco.com

Terms and Provisions

Customer Acceptance By: _____ Printed Name: _____
 Date Signed: _____ PO #: _____
 Requested delivery date: _____ Ship Via: _____
 Terms: _____

Subject to Management approval

Due to the current tariff environment, all quotes are subject to change with a potential tariff surcharge that may be added to the quote. The total surcharge, will be based on tariff surcharges received at the time of the manufacture invoice Please initial here _____

** Subject to all applicable taxes. This proposal is good for 30 days and subject to availability. Pricing is subject to change without notice.*



Road Builders Machinery and Supplies Co.
 Kansas City KS
 Presented by:
Jeremy Manning

Quote #: jpm-0586
 1/14/2026 3:05 PM
 Page 4 of 4
 816-898-9728
 jmanning@rbmsco.com

FINANCING

RoadBuilders offers solutions to your unique financial needs. We have a dedicated financial specialist who will find the financial options that are right for you - comprehensive, flexible, and cost-effective financing.

On the other hand, if you prefer to finance through your bank, we're happy to assist. We can always offer a financing comparison, which sometimes saves you money.

THERE ARE MANY PLANS TO CHOOSE FROM:

- Leasing Options
 - Lease with Fixed Residual
 - Lease with Fair Market Value Option
- Installment Sales Plan

Check out our other lines

* Subject to all applicable taxes. This proposal is good for 30 days and subject to availability. Pricing is subject to change without notice.



MG-CGP

CRAIG GRAVEL PACKER

OWNER'S MANUAL

Important safety and operation instructions inside

Read thoroughly before operating

CRAIG MANUFACTURING LTD.
96 Mclean Ave
Hartland, New Brunswick
E7P 2K5 Canada

Tel: 1-506-375-4493
Toll Free: 1-800-565-5007

Email: sales@craigattachments.com
Website: www.craigattachments.com

HARTLAND BRANCH
96 Mclean Avenue
Hartland, New Brunswick
E7P 2K5 Canada

CAMBRIDGE BRANCH
315 Thompson Drive
Cambridge, Ontario
N1T 2B3 Canada

WATFORD BRANCH
88 27323 TWP Rd 394
Lacombe County, Alberta
T4M 0S1 Canada

LAWRENCEBURG BRANCH
408 Commerce Way
Ethridge, Tennessee
38456 USA

1-800-565-5007 • WWW.CRAIGATTACHMENTS.COM

TABLE OF CONTENTS

PREFACE

INTRODUCTION

SAFETY INSTRUCTIONS

DECALS

INSTALLATION INSTRUCTIONS

OPERATION INSTRUCTIONS

TROUBLESHOOTING

MAINTENANCE

STORAGE

SPECIFICATIONS

PARTS

PREFACE

Congratulations on the purchase of your new Craig Manufacturing Ltd. product. This manual provides safety, operation, and maintenance information. To keep your product in good condition, please read this manual and follow all recommendations. Failure to do so may invalidate your warranty.

When parts or service are necessary contact Craig at 1-800-565-5007 for genuine Craig Parts. Before using your product, make sure your machine is equipped with all the OEM recommended requirements for your product application.

CRAIG FACTORY ORIGINAL PARTS



The best way to ensure equipment reliability is to use only genuine Craig Manufacturing Ltd. Factory Original Parts. Our parts department can help you not only find the right part for your application but also offers advice and support for the repair. Using aftermarket non-approved parts can alter your product's performance characteristics and may affect your warranty.

To help ensure that correct parts are ordered, please record the serial number of your product. Over time serial tags can become tarnished or difficult to read. Please supply this serial number to your dealership when ordering parts and it will ensure the correct part gets ordered.

Serial: _____

Machine: _____

Model: _____

In-Service Date: _____

Purchased From: _____



Never let anyone operate this unit without reading the "SAFETY INSTRUCTIONS" and "OPERATION INSTRUCTIONS" sections of this manual.

NOTE: The illustrations and data used in this manual were current (according to the information available to us) at the time of printing, however, we reserve the right to redesign and change the attachment as may be necessary without notification.

INTRODUCTION

As the new owner and/or operator of the Craig gravel packer we require you take the time to read this Operator's Manual carefully before commencing work.

FOLLOW THE SAFETY INSTRUCTIONS

- Carefully read all the safety information contained in this manual.
- Make sure all safety decals are securely fitted in the cab.
- Immediately replace any safety decals that are missing or damaged.
- Before starting work make sure you have a copy of this Operator's Manual in the cab and are familiar with all the safety procedures and instructions contained in this manual.

INFORMATION FOR THE USER

The user of the Craig attachment is obliged to ensure that the equipment is always in safe working order in accordance with accident prevention regulations, Occupational Safety and Health regulations or any other official instructions.

ENHANCED WARRANTY FOR ELIGIBLE PRODUCTS

Craig offers an enhanced warranty from 12 months (or 2,000 hours which ever comes first) to 36 months (or 6,000 hours) for **eligible products**. To take advantage of this enhanced warranty the eligible product must be registered within 30 days of receiving the product. You can register your product at the following website:

<https://www.craigattachments.com/product-registration/>

Refer to the contents of this manual to remedy faults and contact Craig at 1-800-565-5007 if you require assistance. Notice that unauthorized modifications to this equipment is prohibited and will void warranty.

SAFETY INSTRUCTIONS



This is an alert symbol. It indicates an imminent or potential hazard. Signal words "DANGER", "WARNING", and "CAUTION" qualify this alert symbol into the following categories:



Hazardous situation which, if not avoided, **WILL** result in death or serious injury



Hazardous situation which, if not avoided, **COULD** result in death or serious injury



Hazardous situation which, if not avoided, could result in minor or moderate injury

The signal word "**NOTICE**" indicates important information that, if not followed, could result in severe damage to equipment or property.

SAFETY PRECAUTIONS BEFORE OPERATION

The primary responsibility for safety with this product falls to the operator. Make sure the product is operated only by trained individuals that have read and understood this manual. If there is any portion of this manual or function you do not understand, contact your local authorized dealer, or Craig Manufacturing Ltd. Keep this manual available for reference.



WARNING!



Read Manual Prior to Installation, Operation or Maintenance
Improper installation, operation, and/or maintenance of your Craig Manufacturing Ltd. attachments can cause death or bodily injury, property damage, or damage to your equipment. Read and understand this manual and all labels before operating or doing any work on the equipment. **NEVER** allow anyone to operate this unit without first reading the safety and operating instructions. Failure to do so may affect your warranty.

Read your machines owner's manual and always be aware of capacities and heights of all materials moved are within the machines stated operational capacity.

Understand All Safety Decals and Statements

Become familiar with and inform users about all safety decals and safety statements in all manuals and on the back of the attachment prior to operating or working on this product. Know and follow all national occupational safety regulations, local laws, and other professional guidelines. As well as all good work practices when working on or with this product. Know your equipment capabilities and operations.

Worn, damaged, or illegible safety decals must be replaced. New safety decals can be ordered from your local dealer.

SAFETY INSTRUCTIONS**WARNING!**

Inspect all equipment prior to operating and ensure all components are in proper working order. Check hardware for tightness and that all guards and safety devices are in place. Know all decals and check for legibility. Replace anything damaged, worn or missing. Make sure operator cab is clean and free of any distracting objects or spills.

Be aware of overhead or buried utilities. Contact your local utilities to locate any underground lines or other hazards.

Make sure all levers, pedals, switches, or other controls are in neutral position prior to starting the engine.

Before exiting the machine, for any reason, follow the "MANDATORY SHUT DOWN PROCEDURE".

MANDATORY SHUT DOWN PROCEDURE

1. Stop the machine on level ground.
2. Lower the attachment to the ground.
3. Move throttle to the idle position.
4. Disengage all power to the attachment.
5. Apply the brakes.
6. Turn off the engine and remove the key.

Never use your attachment as a work platform or personnel carrier

Never lift, move, or swing an attachment over anyone.

Do not use attachment for lifting materials outside of its purpose. This attachment is not a lifting device unless approved for your jurisdiction.

Never perform any work on the attachment unless you are authorized and qualified to do so. Work in pairs. Always read the operator service manuals before any repair is made. Wear proper PPE.

**Personal Protective Equipment (PPE) Required**

Remove ignition key and immobilize the machine during installation, inspection, or service. Always follow safe work practices when installing, servicing, or inspecting your product by wearing

only snug-fitting clothing, removing jewelry, and securing long hair. Wear safety goggles to protect your eyes from hydraulic fluid, sparks, dirt, and dust. Always have a fire extinguisher rated BC on hand for flammable liquid and electrical fires. Lastly, always lift with your legs, and use lifting equipment when applicable.

SAFETY INSTRUCTIONS



WARNING!



CRUSH HAZARD – DO NOT work under or around raised arm or attachment.

Lower or Support Unstable/Raised Equipment. NEVER trust that the hydraulic system will not fail. ALWAYS lower booms and attachments to the ground before leaving the cab or operator's station. DO NOT work under or around attachments or heavy items not supported by stands, blocks or safety chains. Furthermore, it is important to use chains and/or stands to steady unstable attachments or heavy components that may fall if being disconnected.



Skin Injection Hazard

- Relieve pressure before working on system
- Wear gloves & eye protection
- Detect leaks with wood or cardboard
- NEVER use hands to detect leaks
- Fluid injected in skin must be surgically removed

Hydraulic Safety

Always inspect hydraulic components before operating your product. Replace any damaged or worn parts immediately. Temperature changes can change hydraulic pressure, which allow the cylinders to drop unexpectedly, causing injury or damaging hydraulic components.

Hydraulic fluid under pressure can cause bodily harm. If you suspect a hydraulic leak note the following:

- The high pressure of the hydraulic lines can cause leaks that can puncture flesh. Therefore, it is important to keep uncovered body parts such as face, eyes, and arms away from a suspected leak.
- Flesh injected with hydraulic fluid may develop gangrene or other permanent disabilities. If injured by leaking hydraulic fluid, see a doctor immediately. Hydraulic fluid could have injected into the wound, and it may not be known.
- Before disconnecting hydraulic lines, wait until the fluid cools down. Hot hydraulic fluid can cause severe burns.
- Always wear protective clothing, such as gloves and safety glasses, and use a piece of cardboard when searching for hydraulic leaks. **DO NOT USE YOUR HANDS.**

Never make hydraulic repairs while the system is under pressure. Serious personal injury or death could occur. Never work under a raised attachment. Check the weight of the attachment and use handling equipment of sufficient capacity.

Always tag "DO NOT OPERATE" until all problems are corrected.

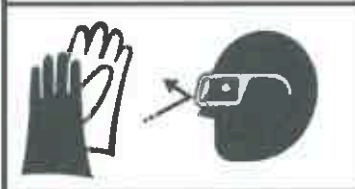

SAFETY INSTRUCTIONS**WARNING!**

Lubricants may contain toxins, cause adverse health effects or be hazardous to the environment. Ensure environmentally safe disposal. Observe all safety labels.

Do Not Alter Attachment

Any alterations to this product could affect the safety and performance of the attachment. When making repairs, use only Craig Manufacturing Ltd. parts, and follow the provided procedures. If the parts and procedures are not used the warranty is void and any alterations may cause the attachment to become unsafe. Any modifications must be authorized in writing by Craig Manufacturing Ltd.

Safe Transport

- Travel only with the attachment in a safe transport position to prevent uncontrolled movement. Drive slowly over rough terrain and slopes.
- When transporting on a trailer, secure attachment using tie downs in recommended locations to maintain attachment stability.
- When driving on public roads use safety lights, reflectors, and slow-moving vehicle signs to prevent accidents. Check local government regulations that may affect you.
- Do not drive close to ditches or excavations, because a cave-in could occur.

Keep attachment close to the ground when engaging/disengaging attachments!

It is possible to drop an attachment during engaging and disengaging procedures. Therefore, it is best to make sure the attachment is kept close to the ground. Visually check that the attachment is securely locked before operating. Follow the procedures outlined in the operation section of this manual. If coupler is not functioning properly, it must be checked/repared by a qualified service technician prior to use. Failure to do so could result in serious injury or death.

SAFETY INSTRUCTIONS**CAUTION!****Remove Paint Before Welding or Heating**

When paint is heated by welding, or by using a torch, hazardous fumes/dust can be generated. Therefore, it is important to do all work in a well-ventilated area and dispose of paint and solvent properly. **TURN OFF ENGINE AND DISCONNECT BATTERY PRIOR TO WELDING.** Refer to machine's owner's manual for procedure.

When removing paint:

- It is important to wear an approved respirator when sanding or grinding paint.
- If you use a paint stripper or solvent, remove the stripper with soap and water.
- Remove solvent or paint stripper containers and other flammable material from the welding/heating area.
- Allow fumes to disperse at least 15 minutes before welding or heating.

DECALS

Item	Part #	Description	Quantity
1	164958-XX	Decal, pinch point hazard	1
2	164953-XX	Decal, grease frequently	1
3	159025-XX	Decal, pressure setting	1
4		Decal, accumulator (see manufacturer)	1

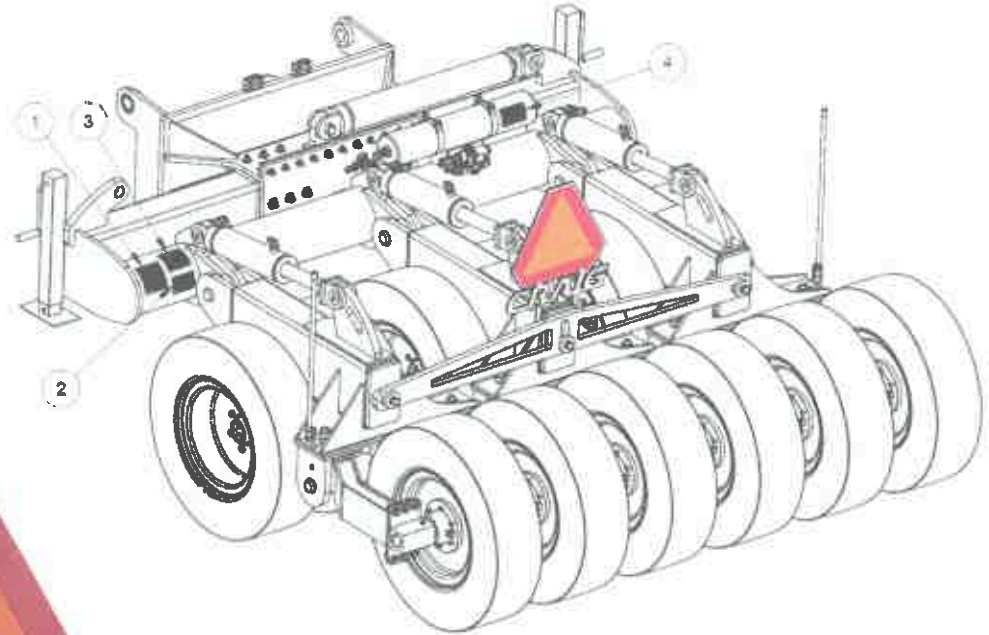

! DANGER



PINCH POINT HAZARD

164958-EN

NOTICE



Grease frequently 164953-EN

NOTICE

This attachment must be connected to a valve section that is set no higher than:

2500 PSI

159025-EN

INSTALLATION INSTRUCTIONS

NOMENCLATURE

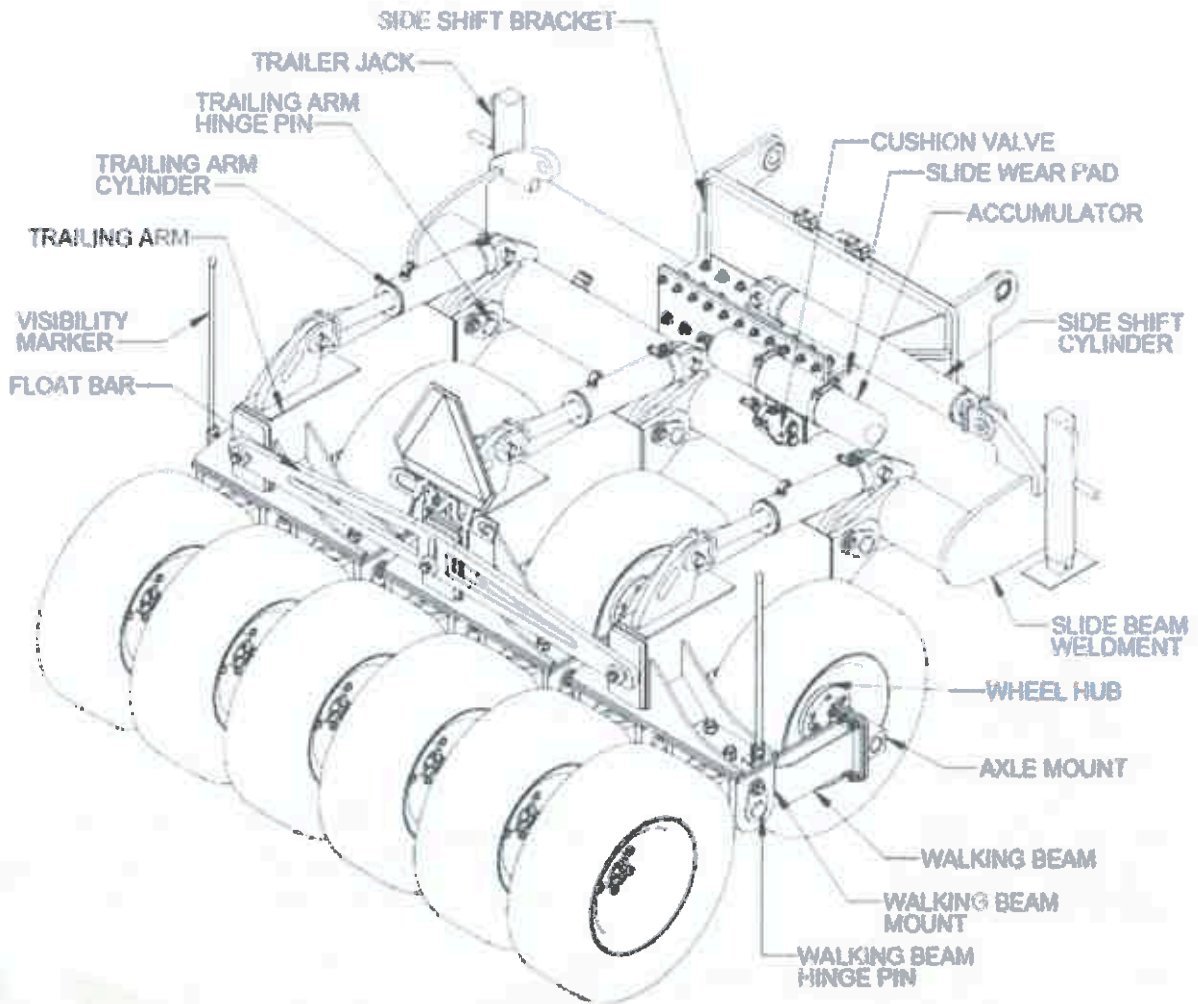

NOTE: YOUR PRODUCT MAY NOT APPEAR EXACTLY AS SHOWN

Accumulator:

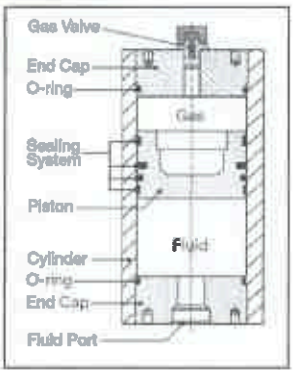

INSTALLATION INSTRUCTIONS

TERMINOLOGY

Cushion Valve:	This crossover relief valve provides pressure overload protection for hydraulic cylinders. Relieved oil is directed to the opposite side of the relief (crossover), which prevents cavitation of the cylinder.
Accumulator:	The accumulator uses pressurized gas to absorb shock loads in the hydraulic system. When hydraulic fluid is forced into the accumulator the piston compresses the gas increasing pressure. The energy of the shock load is stored and released similar to a spring.
Side shift cylinder:	Allows entire packer to shift to one side. The cylinder can be mounted on the opposite side of the bracket to shift in the opposite direction.
Side shift bracket:	Mounts to machine and holds the slide beam that shifts.
Slide beam weldment:	The beam that shifts hydraulically and holds the trailing arms.
Slide wear pad	Wear pads on each side of the slide beam allow for smooth side shifting.
Trailer jack:	Jack for supporting the packer when disconnected from the machine.
Trailing arm:	The arm that supports the packer elements.
Trailing arm cylinder:	Cylinder that lifts or provides down pressure to the trailing arm.
Trailing arm hinge pin:	Hinge point between trailing arm and slide beam.
Walking beam:	The pivoting beam that follows the contour of the road.
Walking beam mount:	The hinge mount between the walking beam and the trailing arm.
Walking beam hinge pin:	Hinge point between walking beam and beam mount.
Axle mount:	Removable axle for each wheel to mount to the walking beam.
Wheel hub:	Supports the wheel on a sealed bearing for the fixed axle.

INSTALLATION AND REMOVAL

Read all safety precautions before installing the attachment. Refer to the machine's owner's manual for additional information. If a coupler system is involved ensure that the coupler is working properly before use. In addition, refer to the manufacturer for the coupler owner's manual to familiarize yourself with its proper procedures and operations. Craig coupler owner's manuals can be found by going to:

www.craigattachments.com/technicaldocuments

INSTALLATION INSTRUCTIONS

HYDRAULICS

There is a cushion valve and accumulator for the trailing arm cylinders of the packer. See hydraulic schematic below:

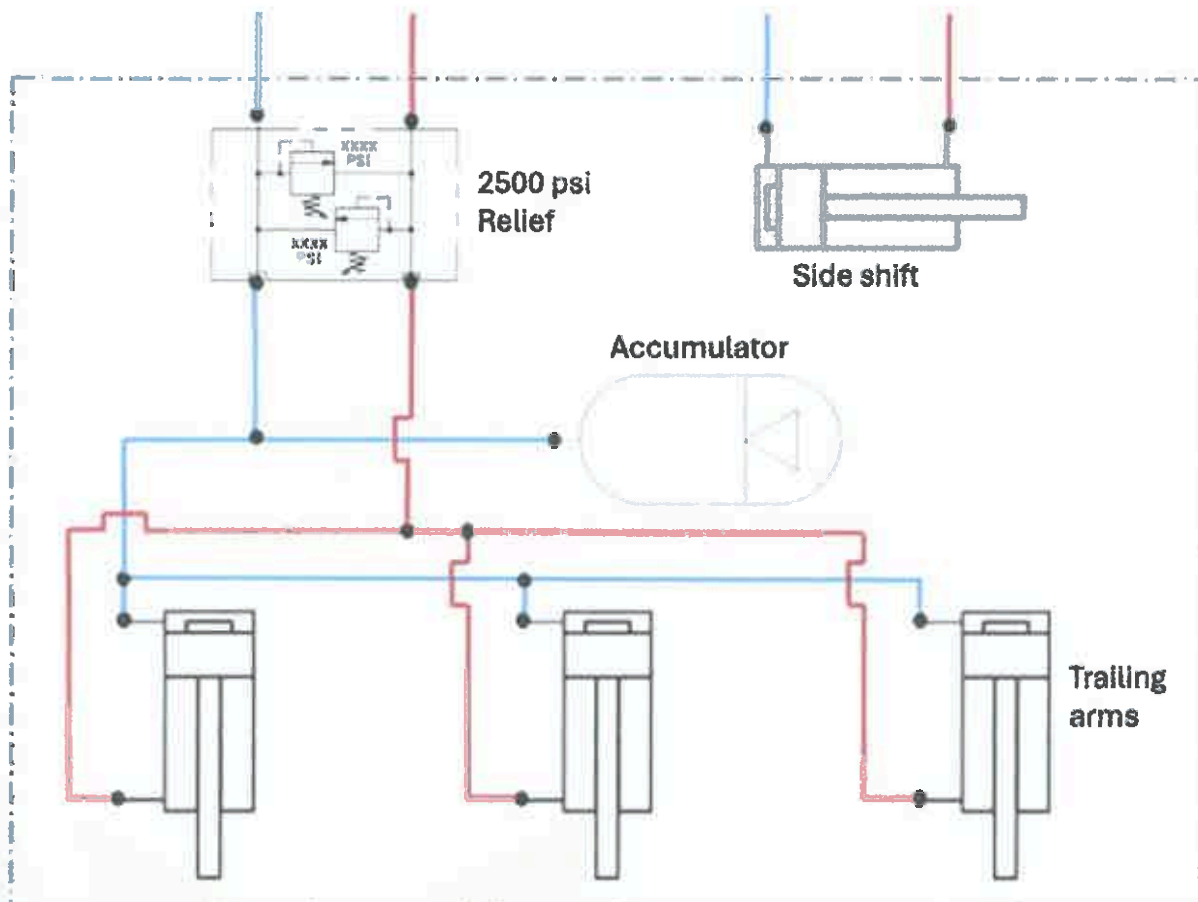
**NOTICE**

This attachment must be connected to a valve section that is set no higher than 2500 psi. This will ensure that the hydraulic circuit will always relieve before damaging the packer. The accumulator must be connected to the barrel end of the trailing arm cylinders to absorb shock loads.

INSTALLATION INSTRUCTIONS

ADJUSTING WHEEL SPACING

The packer wheels should be spaced apart from each other enough to clear the trailing arm, but not too much that they create windrows. The spacing can be adjusted by loosening the six bolts for the axle mount and shifting the slotted plate, or by loosening the two walking beam mount bolts to adjust the angle of the walking beam. See below:

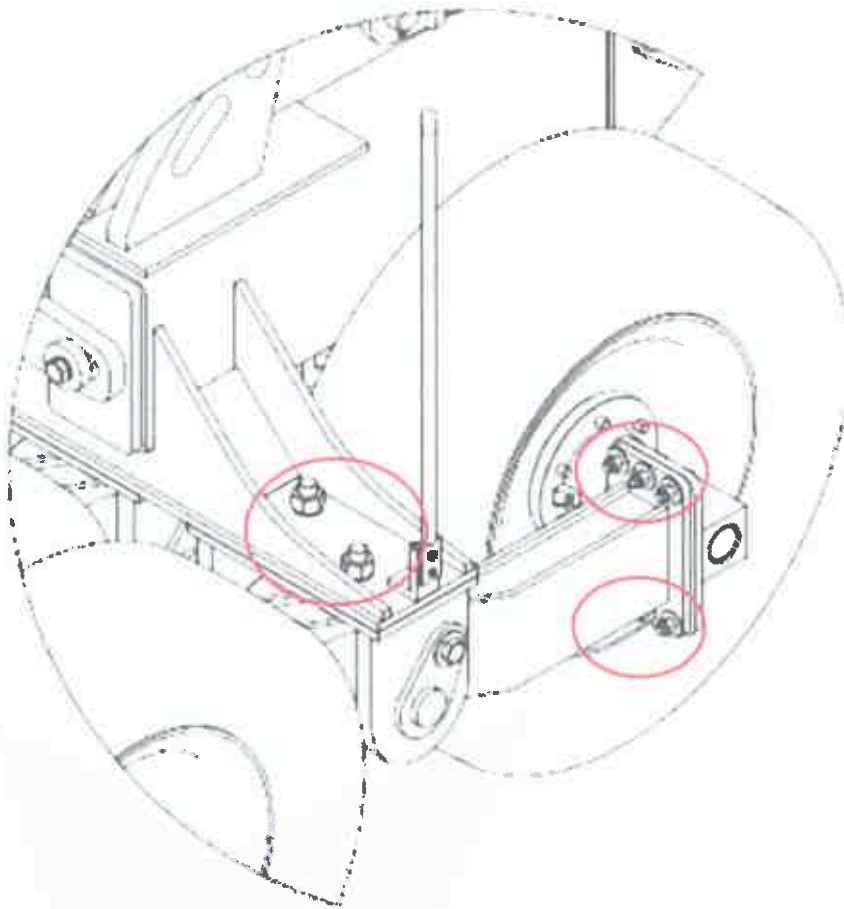

OPERATION INSTRUCTIONS

INTENDED USE

Craig Gravel Packers are intended for dirt and gravel road compaction. Use outside of this scope is considered misuse.



WARNING

Operator and maintenance personnel must be trained and familiar with the entire manual. The operator is responsible for safety. If there is any portion of this manual or function you do not understand, contact your local authorized dealer, or Craig Manufacturing Ltd.

PRIOR TO OPERATION

- Inspect machine and all equipment prior to use. Refer to “MAINTENANCE” section and perform all periodic inspections and maintenance.
- Ensure operator cab is clean and free of distracting objects or spills.
- No passengers allowed.
- Make sure all levers, pedals, switches, or other controls are in neutral position prior to starting the engine.

OPERATION

- The operator should be familiar with all controls. Refer to the machine owner's manual for further operation instructions.
- DO NOT attempt to make sharp turns while packer is lowered. Raise packer before making sharp turns.



CAUTION

Steering loss may occur if using the front grader circle moldboard while packer is raised. The counterweight of the packer combined with the down-pressure of the front moldboard takes weight off the front wheels.

TROUBLESHOOTING

Problem	Possible Cause	Remedy
Cracks in steel structure or weld	Overloading or side loading	Immediately stop use and contact Craig Tech Support at 1-800-565-5007
Cylinder is slow or fails to actuate	Leaking hose or fittings	Check for pinched hose or damaged fittings. Refer to safety instructions for proper procedure to check for leaks.
	Insufficient hydraulic flow	Recommended flow is 25 GPM
Excessive wear on pins	Lack of grease	Ensure all pins are greased regularly. Replace any worn parts.
Packer creates windrows	Wheels are unevenly spaced or too far apart	Adjust the walking beams or axles. See installation section.

MAINTENANCE

GENERAL INFORMATION

It is the operator's responsibility to inspect all equipment daily. Regular maintenance is necessary to prolong the life of the equipment, avoid costly shutdowns, and keep things running optimally.



WARNING Operator and maintenance personnel must be trained and familiar with the entire manual. Refer to the "SAFETY INSTRUCTIONS" section and follow the "MANDATORY SHUTDOWN PROCEDURE" prior to doing any work on the machine.

PERIODIC MAINTENANCE TABLE		
Procedure	Daily	Weekly
Clean attachment of debris prior to inspection, especially around cylinder.	X	
Inspect all equipment for damage, worn parts, cracked welds, etc. If a crack is found in either the steel structure or welds, the attachment must be removed from the machine and Craig Contacted immediately. <i>Contact Craig Tech Support (1-800-565-5007) for recommended weld procedures.</i>	X	
Check pins and bushings for play or wear. Replace if worn	X	
Hardware - replace missing or damaged bolts/fasteners, tighten as necessary	X	
Check for kinked/pinched or worn hoses. <i>Repair/reroute as necessary</i>	X	
Hoses - check for leaks. <i>Repair/tighten as necessary</i>	X	
Decals - replace worn or missing	X	
Lubricate grease points	X	
Ensure daily checks are completed		X
Check slide wear pads for excessive wear. Replace if worn		X
Lubricate wheel hubs. DO NOT over-grease. Damage to seal or bearings can result.	Annually	



HARTLAND BRANCH
96 McLean Avenue
Hartland, New Brunswick
E7P 2K5 Canada

CAMBRIDGE BRANCH
315 Thompson Drive
Cambridge, Ontario
N1T 2B3 Canada

BLACKFALDS BRANCH
88 27323 TWP Rd 394
Lacombe County, Alberta
T4M 0S1 Canada

LAWRENCEBURGH BRANCH
408 Commerce Way
Ethridge, Tennessee
38456 USA

1-800-565-5007 • WWW.CRAIGATTACHMENTS.COM

PARTS

To provide you with the most UP-TO-DATE part information, parts diagrams for this attachment have been moved to our Portal website. Please use these diagrams and parts lists to locate your replacement parts.

<https://portal.craigattachments.com/>

When servicing your attachment, remember to use only original manufacturer replacement parts. Substitute parts may not meet the standards required for safe and dependable operation.

To facilitate parts ordering when contacting any of our branches, please have the product serial number or product part number for your attachment ready to ensure that you receive the correct parts for your attachment.

The product serial number and product part number for your attachment should be recorded in the space provided in this manual. This information may be obtained from the serial number identification plate located on your attachment.



NOTE: Most parts orders (in stock) received by 12:00pm (Atlantic Standard Time) can be shipped the same day or following business day.

WARRANTY

To provide you with the most UP-TO-DATE warranty information, warranty procedures, technical documents, product terms, and product registration, please go to our website at:

<https://www.craigattachments.com/>

SPECIFICATIONS

TORQUE CHART - COURSE THREAD									
Nominal Dia. (in.)	Threads per inch	 SAE J429 Grade 5				 SAE J429 Grade 8			
		Clamp Load (lbs.)	Tightening Torque (ft-lbs)			Clamp Load (lbs.)	Tightening Torque (ft-lbs)		
			Lubricated K = 0.15	Thread-locker K = 0.17	Zinc & Dry K = 0.20		Lubricated K = 0.15	Thread-locker K = 0.17	Zinc & Dry K = 0.20
1/4	20	2029	6.3	7.2	8.5	2864	9.0	10.1	11.9
5/16	18	3342	13	15	17	4719	18	21	25
3/8	16	4940	23	26	31	6974	33	37	44
7/16	14	6777	37	42	49	9568	52	59	70
1/2	13	9046	57	64	75	12771	80	90	108
9/16	12	11599	82	92	109	16375	115	130	154
5/8	11	14408	113	128	150	20340	159	180	212
3/4	10	21322	200	227	267	30101	282	320	376
7/8	9	29436	322	365	429	41556	455	515	606
1	8	38616	483	547	644	54517	681	772	909
1 1/4	7	53786	840	952	1121	87220	1363	1545	1817
1 3/8	6	64096	1102	1249	1469	103939	1786	2025	2382
1 1/2	6	77991	1462	1657	1950	126473	2371	2688	3162

Refer to serial tag on the attachment for identification. NOTE: your serial tag may not appear exactly as shown below.



STORAGE

**WARNING**

Disconnection from the machine and installation must be done by a qualified technician. NEVER trust that the hydraulic system will not fail. ALWAYS lower booms and attachments to the ground before leaving the cab or operator's station. DO NOT work under or around attachments or heavy items not supported by stands, blocks or safety chains. Furthermore, it is important to use chains and/or stands to steady unstable attachments or heavy components that may fall if being disconnected.

END OF SEASON

- Thoroughly clean the attachment.
- Inspect for damage and order any replacement parts.
- Tighten all hardware and make sure there are no loose connections.
- Paint all replacement parts.
- Paint any bare surfaces to prevent rust.
- Lubricate all grease points. Refer to maintenance section.
- Apply penetrating oil/rust inhibitor to trip assembly.
- Coat exposed portions of cylinder rods with grease.
- Seal hydraulic system from contaminants.
- Secure all hoses in a manner that prevents potential damage during transport.
- Replace any illegible or missing decals.
- Store unit inside a clean, dry area to prolong life.

BEGINNING OF SEASON

- Review entire operator's manual.
- Clean equipment
- Install any replacement parts.
- Secure all fasteners.
- Check hydraulic hoses for damage and replace as necessary.
- Replace missing or illegible decals.
- Refer to installation section for important information.
- Fully understand this manual and the prime mover operator's manual and take proper precautions prior to testing.

MAINTENANCE

ACCUMULATOR

The accumulator must be depressurized prior to removal or shipping. Repressurization must be done on-site using a charge kit. Contact Craig Tech Support (1-800-565-5007) if any service is required for the accumulator.



Pressurized Vessel

- Gasses under pressure
- **Risk of explosion.** Only nitrogen may be used as a charging gas. No other gases are permitted.
- **Risk of bursting.** On no account may any welding, soldering or mechanical work be carried out on the pressure equipment.
- **Risk of suffocation.** Pressure equipment contains nitrogen. Do not open the pressure equipment unless the pressure has been released from both the fluid side and the gas side.
- **Risk of burns.** The pressure equipment can become hot.

TECHNICAL SUPPORT

If you have followed the maintenance instructions contained in this manual, you should have years of trouble-free operation from your Craig attachment. Should you encounter any issue or have any questions about your attachment please contact us at 1-800-565-5007 and ask for technical support.

READING PRODUCT TAG

Craig Manufacturing Ltd. stamps a blue serial tag onto every attachment. The tag is often located on the rear of the attachment in the upper left corner. The information contained on this tag will be required for parts and support. Craig serial numbers begin with a "T" followed by the year then month of construction. For example, T1203 would denote the year 2012 and 03 the month of March.

MAINTENANCE

LUBRICATION

Greasing the pivot points on your attachment daily with use will help to ensure smooth operation over its lifetime. A well-greased point keeps the metal-to-metal contact to a minimum and with it minimizes wear. A proper greasing technique involves pumping grease onto the fitting until you can visibly see the grease coming out around the joint. It is important to have grease come out into the gap in the joint because it protects the area surrounding from dirt getting in and causing abrasive wear on the metal surfaces in the joint. There are two grease points on each walking beam and three grease points on the sliding beam.

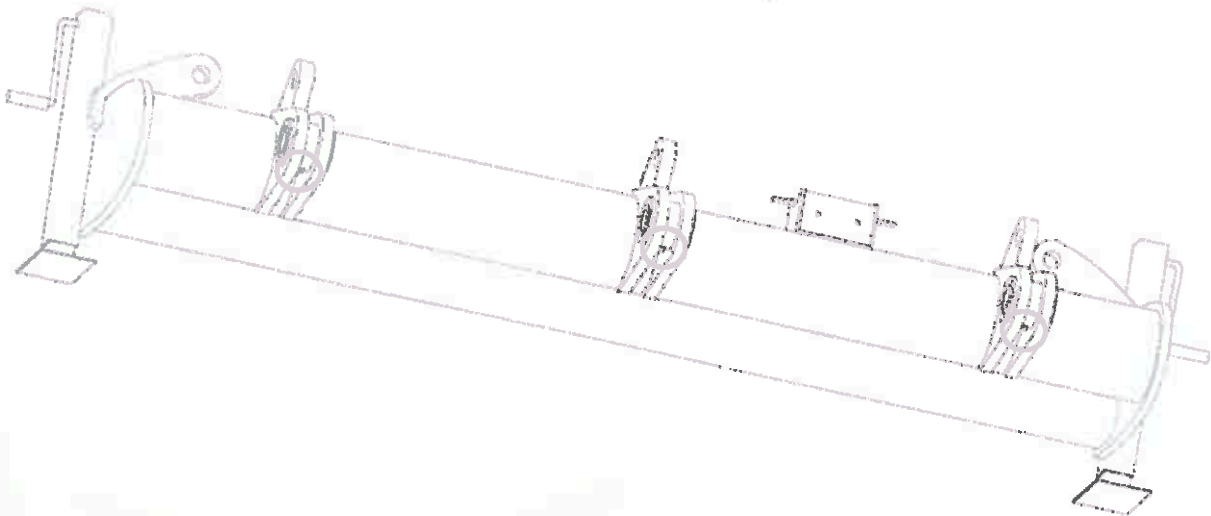
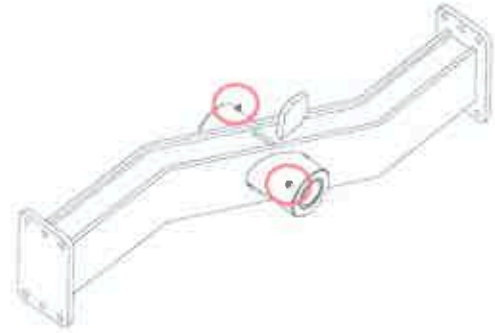
**NOTICE**

Each wheel hub has a grease point. DO NOT over-grease. These should only be greased annually. Damage can result to seals or bearings if more than 70% of cavity is filled.

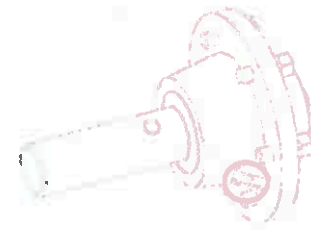

Certified Copy of Record

STATE OF MISSOURI, }
County of Cass, } ss.

In the County Commission of Cass County, Missouri, at the January Term, 2026, held on the 18th day of February 2026 amongst others, were the following proceedings:

RESOLUTION NO. 26-17 OF THE CASS COUNTY COMMISSION

A RESOLUTION ACCEPTING THE BID OF REDFORD CONSTRUCTION, INC. AND AUTHORIZING EXECUTION OF A CONTRACT FOR THE DAVIDSON ROAD CULVERT REPLACEMENT PROJECT

NOW, THEREFORE, BE IT HEREBY RESOLVED AND ORDERED BY THE COUNTY COMMISSION OF CASS COUNTY, MISSOURI, THAT, the bid of Redford Construction, Inc., in the amount of \$328,067.00 for the Davidson Road Culvert Replacement project, is hereby accepted. The alternate bid for asphalt pavement is not awarded. The Presiding Commissioner is hereby authorized to execute the Contract and related documents on behalf of Cass County, Missouri, subject to receipt of:(a) executed Contract documents;(b) properly executed Performance and Payment Bonds; and(c) Certificates of Insurance, as required by the bid documents and Notice of Award. County staff is authorized to take all further actions necessary to carry out the intent of this Resolution.

ADOPTED BY THE COUNTY COMMISSION OF CASS COUNTY, MISSOURI, THIS 18TH DAY OF FEBRUARY 2026.

Bob Huston
Presiding Commissioner

Mike Moreland
Associate Commissioner
Dist. 1

Jeff Fletcher
Associate Commissioner
Dist. 2

ATTEST:



Kathy Lambertz
County Clerk
Dated: _____



102 E. Wall St., Harrisonville, Mo 64701

FEBRUARY 5, 2026

Redford Construction, Inc.
P.O. Box 1065
Raymore, MO 64083

RE: Notice of Award
Cass County Culvert Replacement
Davidson Road

You are notified that your bid dated January 21, 2026 for the referenced contract has been evaluated. Your organization has been determined to be the lowest, responsive, responsible bidder and has been awarded the contract for the work as itemized on your bid form.

The contract price of your Contract is Three hundred twenty eight thousand sixty seven dollars and 00/100 (\$328,067.00). The alternate bid for asphalt pavement will **NOT** be awarded.

Enclosed are the required contract documents for execution by your firm. Cass County will return one set of Contract Documents to you after these are executed by the County Commission.

Your organization shall comply with the following conditions precedent within the number of days after receipt of the Notice of Award specified in the Instructions to Bidders, that is within fifteen (15) calendar days, you shall:

- Sign and return the executed Contract.
- Sign and return the executed Performance and Payment Bonds with acknowledgement by surety and power of attorney for your insurance provider.
- Submit Certificate of Insurance.

Failure to comply with these conditions within the time specified may entitle the Owner to consider your Bid abandoned, annul this Notice of Award and declare your Bid Security forfeited.

Sincerely,

Bob Huston
Cass County Commission

Mike Moreland
District 1 Commissioner

Bob Huston
Presiding Commissioner

Jeff Fletcher
District 2 Commissioner

Certified Copy of Record

STATE OF MISSOURI, }
County of Cass, } ss.

In the County Commission of Cass County, Missouri, at the July Term, 2026, held on the 18th day of February 2026 amongst others, were the following proceedings:

**CASS COUNTY, MISSOURI
ORDINANCE NO. 26-04**

**AN ORDINANCE AUTHORIZING THE TEMPORARY POSTING OF CERTAIN SPEED LIMITS
IN CONNECTION WITH HIGHWAY 7 CONSTRUCTION WORK.**

**BE IT ORDAINED BY THE COUNTY COMMISSION OF CASS COUNTY, MISSOURI, AS
FOLLOWS:**

Section 1. That the Road and Bridge Director is hereby authorized to cause the posted speed limit to be 25 MPH on the following routes:

1. Purvis Road: From RT 58 to RT P
2. 203rd Street: From Raffurty to Purvis Road

Section 2. That the temporary speed limit postings shall be removed when the Road and Bridge Director determines that, in connection with the Highway 7 construction work, it is appropriate to do so based on traffic safety considerations.

Section 3. That violation of this Ordinance is punishable as set forth in County Code Section 1000.210, which is incorporated herein by reference as if fully set forth.

Section 4. That this Ordinance shall be effective upon its approval.

ADOPTED BY THE CASS COUNTY COMMISSION THIS 18TH DAY OF FEBRUARY 2026.

Bob Huston
Presiding Commissioner

Mike Moreland
Associate Commissioner,
District 1

Jeff Fletcher
Associate Commissioner,
District 2

ATTEST:

Kathy Lambertz
County Clerk
Dated: _____



CHRIS MOLENDORP
CASS COUNTY COLLECTOR



Chief Deputy Collector
Lori Brumitt

Deputy Collector
Kelsi Youngblood

Steve Cheslik, Cass County Treasurer

February 3, 2026

RE: Requesting Disbursement of 2024 Tax Sale Surplus Monies

Certificate of Purchase # 24-01 Tax Sale # 59

Taxpayer Name: Samantha & Jack Burton-Wilson

Amount: \$ 37,067.92 Payable to: Amanda Butler

Respectfully Submitted: *Chris Molendorp*
Cass County Collector

District 1 Commissioner

Presiding Commissioner

District 2 Commissioner

Date _____

Date _____

Date _____